



Sweden

SKOGSINDUSTRIERNAS
TEKNIK AB

Pulp and Paper Industries' Engineering Co

SSG 1809 E

Date
1988-10-01

Edition
3

Designation
TKRR

Page
1(2)

Pipe fittings of chemical-resistant, glassfibre-reinforced, unsaturated ester plastic for process pipes. GAP pipe fittings. Connection sleeve with collar. PN 6 and PN10

Introduction

This edition differs from Edition 2 mainly through having been adapted to the Swedish Plastic Piping Code and the corresponding Finnish Standards in this sector.

1 Designation

**Connection sleeve with collar SSG 1809- Inner diameter - Pressure class -
- Type of plastic - (Reinforced)¹⁾**

1.1 Example

Connection sleeve with collar SSG 1809- 100 - PN6 - Vinyl ester

¹⁾ If reinforced inner and barrier layers are required this must be specified in the designation.

2 Requirements

2.1 General

2.1.1 Material

According to the Swedish Plastic Piping Code where applicable.

2.1.2 Manufacture

According to the Swedish Plastic Piping Code where applicable.

2.1.3 Marking

Connection sleeves with collars shall be marked with the following information:

- Manufacturer's name or trade mark
- Type of plastic
- Pressure class (PN)
- Standard or type approval number
- Dimension (Inner diameter D_i /Inner diameter d_i)
- Manufacturing date (year and month)

2.1.4 Flatness

According to Table 1.

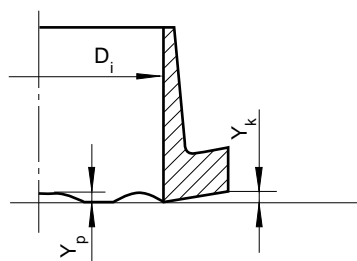

2.2 Dimensions

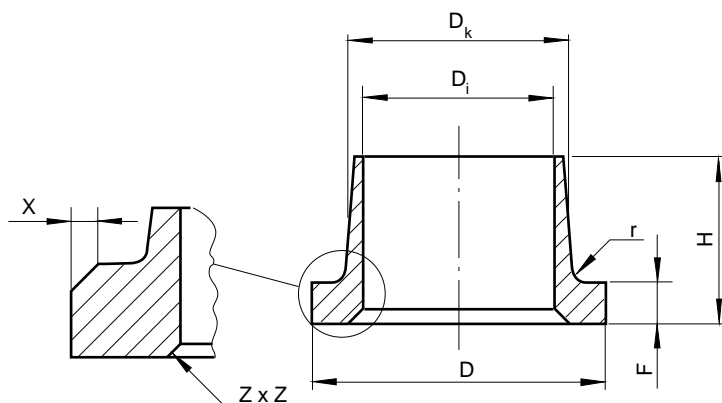

Postal address
Box 140, S-851 03 Sundsvall

Phone
060-12 38 50

Telefax
060-15 07 10

Number of app.