



Pipe fittings of chemical-resistant, glassfibre-reinforced, unsaturated ester plastic for process pipes. GAP pipe fittings. Tapers

Introduction

This edition differs from Edition 2 mainly through having been adapted to the Swedish Plastic Piping Code and the corresponding Finnish Standards in this sector.

1 Designation

Taper SSG 1808 - Type - Inner diameter (D_i)/Inner diameter (d_i) - Pressure class - Type of plastic - (Reinforced)¹⁾

1.1 Example

Taper SSG 1808 - C - 80/50 - PN1 - Vinyl ester

¹⁾ If reinforced inner and barrier layers are required this must be specified in the designation.

2 Requirements

2.1 General

2.1.1 Material

According to the Swedish Plastic Piping Code where applicable.

2.1.2 Manufacture

According to the Swedish Plastic Piping Code where applicable.

2.1.3 Marking

Tapers shall be marked with the following information:

- Manufacturer's name or trade mark
- Type of plastic
- Pressure class (PN)
- Standard or type approval number
- Dimension (Inner diameter D_i /Inner diameter d_i)
- Manufacturing date (year and month)

2.1.5 Edge deviation

Maximum edge deviation Q as indicated below.

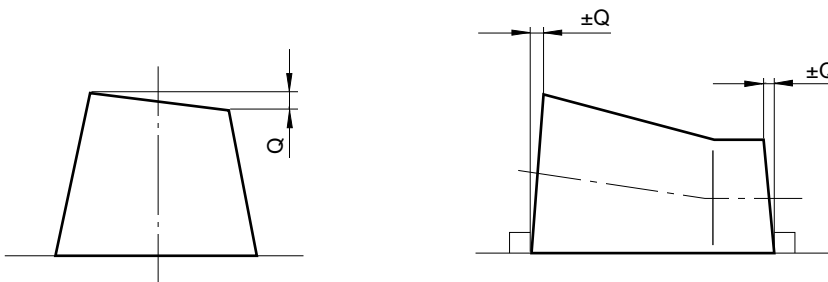

D_i (mm)	Q_{max} (mm)
≤ 250	3
> 250 ≤ 600	6

2.2 Dimensions

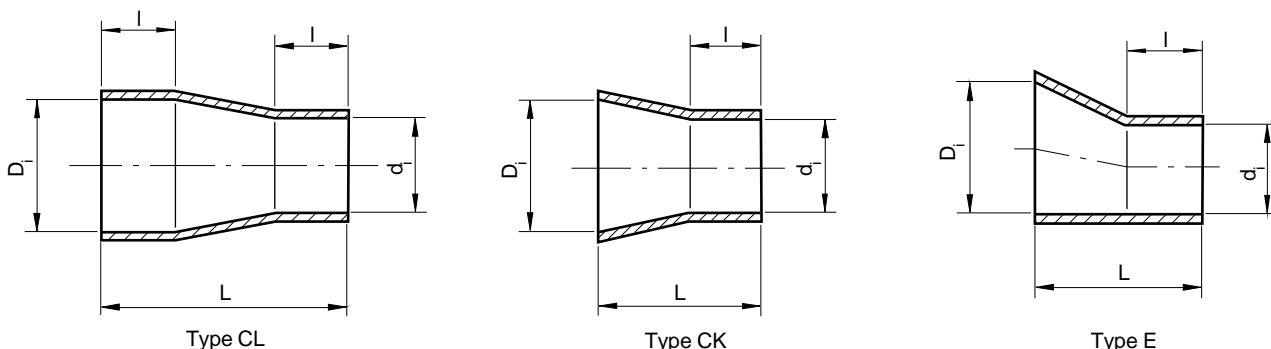

Postal address Box 140, S-851 03 Sundsvall	Phone 060-12 38 50	Telefax 060-15 07 10	Number of app.
-----------------------------------------------	-----------------------	-------------------------	----------------