



Pipe fittings of chemical-resistant, glassfibre-reinforced, unsaturated ester plastic for process pipes. GAP pipe fittings. Tees

Introduction

This edition differs from Edition 2 mainly through having been adapted to the Swedish Plastic Piping Code and the corresponding Finnish Standards in this sector.

1 Designation

Tee SSG 1807 - Inner diameter (D_i)/Inner diameter (d_i) - Pressure class - Plastic type - (Reinforced)¹⁾

1.1 Example

Tee SSG 1807 - 50/50 - PN1 - Vinyl ester

¹⁾ If reinforced inner and barrier layers are required this must be specified in the designation.

2 Requirements

2.1 General

2.1.1 Material

According to the Swedish Plastic Piping Code where applicable.

2.1.2 Manufacture

According to the Swedish Plastic Piping Code where applicable.

2.1.3 Marking

Tees shall be marked with the following information:

- Manufacturer's name or trade mark
- Type of plastic
- Pressure class (PN)
- Standard or type approval number
- Dimension (Inner diameter D_i /Inner diameter d_i)
- Manufacturing date (year and month)

2.1.5 Edge deviation

Maximum edge deviation Q as indicated below.

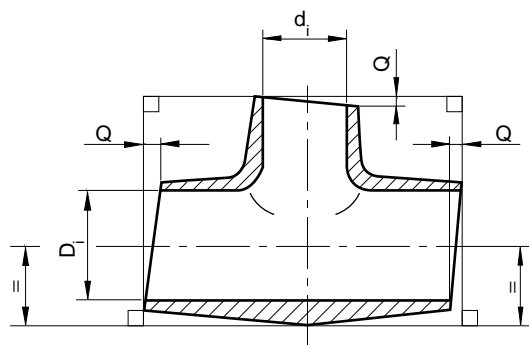

D_i (mm)	Q_{max} (mm)
≤ 250	3
$> 250 \leq 600$	6

2.2 Dimensions

