



Piping of chemical-resistant, glassfibre-reinforced, unsaturated ester plastic for process pipes. GAP pipe fittings. Pipe bends

Introduction

This edition differs from Edition 2 mainly through having been adapted to the Swedish Plastic Piping Code and the corresponding Finnish Standards in this sector.

1 Designation

Pipe bend SSG 1806 - Inner diameter (D_i) - Pressure class - Type of plastic - (Reinforced)¹⁾

1.1 Example

Pipe bend SSG 1806 - 50 - PN1 - Vinyl ester

¹⁾ If reinforced inner and barrier layers are required this must be specified in the designation.

2 Requirements

2.1 General

2.1.1 Material

According to the Swedish Plastic Piping Code where applicable.

2.1.2 Manufacture

According to the Swedish Plastic Piping Code where applicable.

2.1.3 Marking

Pipe bends shall be marked with the following information:

- Manufacturer's name or trade mark
- Type of plastic
- Pressure class (PN)
- Standard or type approval number
- Dimension (inner diameter x material thickness)
- Manufacturing date (year and month)

2.1.5 Edge deviation

Maximum edge deviation Q as indicated below.

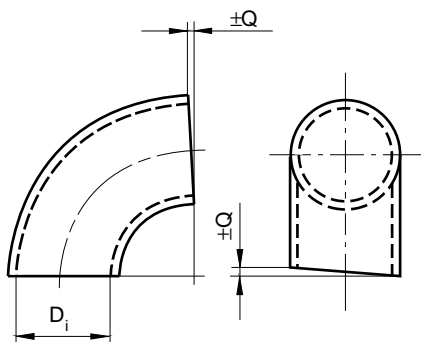

D_i (mm)	Q_{max} (mm)
≤ 250	3
$> 250 \leq 600$	6

2.2 Dimensions

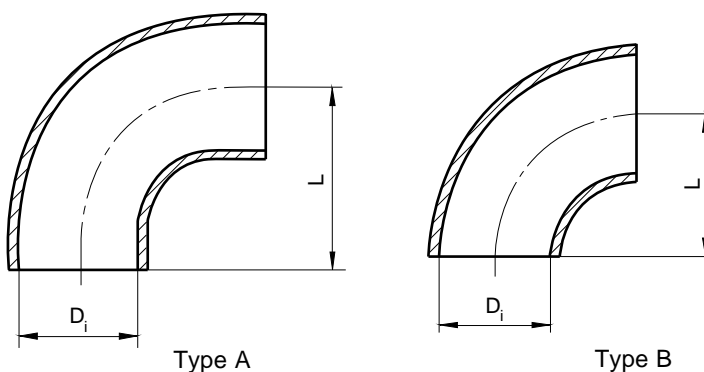

Postal address Box 140, S-851 03 Sundsvall	Phone 060-12 38 50	Telefax 060-15 07 10	Number of app.
---	-----------------------	-------------------------	----------------